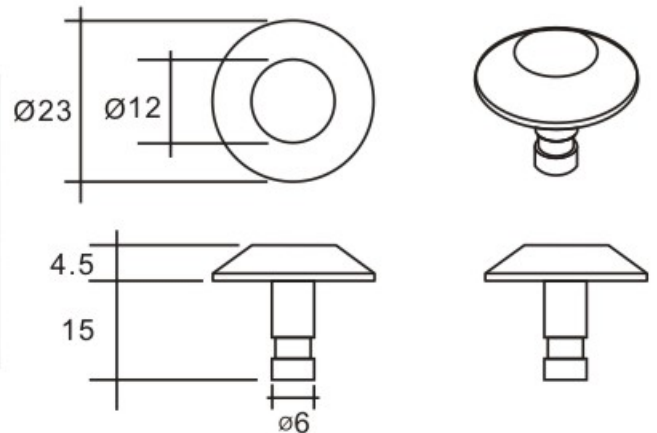
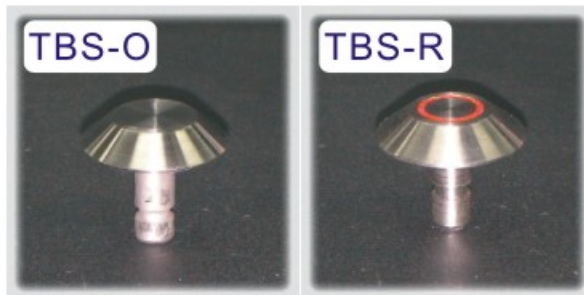
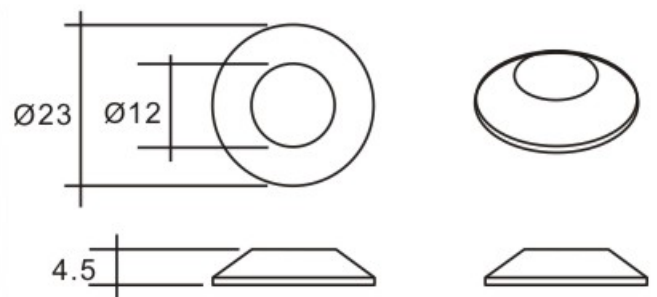
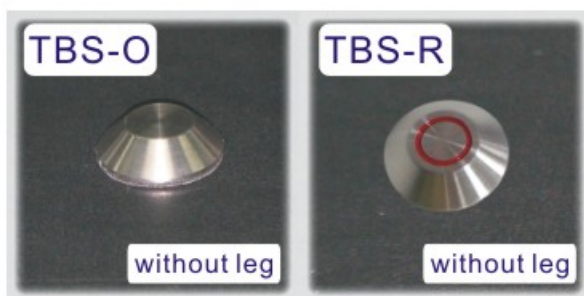

不銹鋼導行裝置 [Small Tactile Bolt]
Stainless Steel Tactile System [Small Tactile Bolt]

 Small Tactile Bolt
 有腳 [With Leg]

<u>Material:</u>	<input type="checkbox"/> S.S.304	<input type="checkbox"/> S.S.316	<u>Type:</u>	<input type="checkbox"/> Solid	<input type="checkbox"/> Shell
<u>Installation:</u>	<input type="checkbox"/> Epoxy	<input type="checkbox"/> Double Side Tape (Industrial use waterproof double side tape)			
<u>Color:</u> (For TBS-R model only)	<input type="checkbox"/> None	<input type="checkbox"/> Red	<input type="checkbox"/> Other: _____		

 Small Tactile Bolt
 無腳 [Without Leg]

<u>Material:</u>	<input type="checkbox"/> S.S.304	<input type="checkbox"/> S.S.316			
<u>Installation:</u>	<input type="checkbox"/> Epoxy	<input type="checkbox"/> Double Side Tape (Industrial use waterproof double side tape)			
<u>Color:</u> (For TBS-R model only)	<input type="checkbox"/> None	<input type="checkbox"/> Red	<input type="checkbox"/> Other: _____		

如需更多資料或有任何疑問，請與我們聯絡。
 For more information, please contact us.
 Tel : (852) 2873 2804 , E-mail : sung@sunwayltd.com.hk
 Fax: (852) 2814 0776 , Website : http://www.sunwaymetal.com/

不銹鋼導行裝置 [Large Tactile Bolt]
Stainless Steel Tactile System [Large Tactile Bolt]

Large Tactile Bolt
有腳 (With Leg)

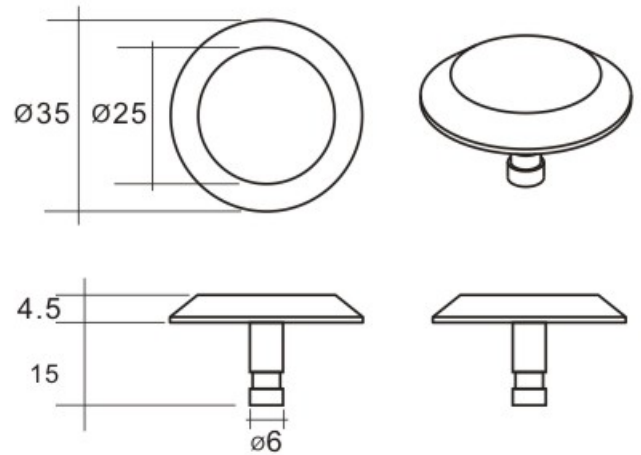

<u>Material:</u>	<input type="checkbox"/> S.S.304	<input type="checkbox"/> S.S.316	<u>Type:</u>	<input type="checkbox"/> Solid	<input type="checkbox"/> Shell
<u>Installation:</u>	<input type="checkbox"/> Epoxy	<input type="checkbox"/> Double Side Tape (Industrial use waterproof double side tape)			
<u>Color:</u> (For TBL-R and TBL-2R model only)	<input type="checkbox"/> None	<input type="checkbox"/> Red	<input type="checkbox"/> Other: _____		

Large Tactile Bolt
無腳 (Without Leg)

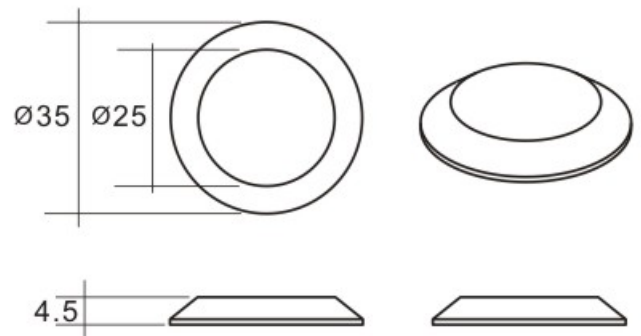

<u>Material:</u>	<input type="checkbox"/> S.S.304	<input type="checkbox"/> S.S.316			
<u>Installation:</u>	<input type="checkbox"/> Epoxy	<input type="checkbox"/> Double Side Tape (Industrial use waterproof double side tape)			
<u>Color:</u> (For TBL-R and TBL-2R model only)	<input type="checkbox"/> None	<input type="checkbox"/> Red	<input type="checkbox"/> Other: _____		

如需更多資料或有任何疑問，請與我們聯絡。
For more information, please contact us.
Tel : (852) 2873 2804 , E-mail : sung@sunwayltd.com.hk
Fax: (852) 2814 0776 , Website : http://www.sunwaymetal.com/

不銹鋼導行裝置 [TBL-2RC] Stainless Steel Tactile System [TBL-2RC]

導行裝置TBL-2RC 適用於戶外及室內
已安裝於灣仔太古廣場第3期之行人路上歷時2年多，依然保持光潔如新。



拍於2006年底剛安裝不久

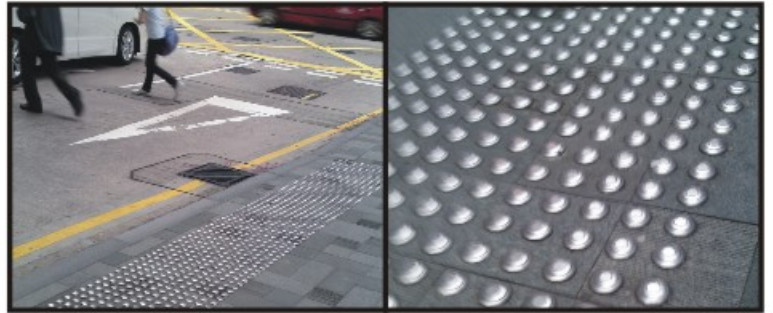

拍於2009年3月

現有黃色，紅色及黃色夜光3種選擇，更能突出其提示功能。

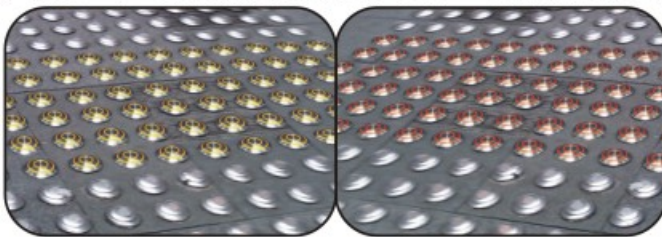

黃色導行釘

紅色導行釘

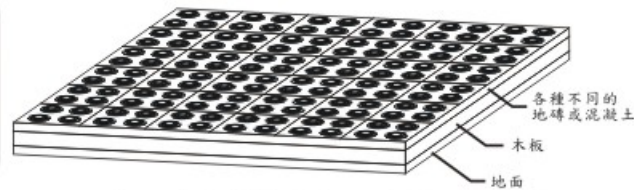

可於廠內先組裝導行釘於地磚上，然後可整塊安裝板送出工地安裝

塗上顏料後之導行裝置(TBL-2RC)已經過廠內之耐久測試

我司於廠內模擬自然環境中，測試導行釘受到外來物如：泥土、水及模擬腳踏後的壽命測試：

- 模擬情況：
- 1) 每天模擬人在導行釘上踏行之狀況，測試其*顏料壽命
時間約每2秒一步，每分鐘有30步，一天內進行10小時測試，即一天約有18000步
 - 2) 測試場地每天曝露於陽光下，隔數小時後更以水及灰塵沙土等覆蓋，如像雨水及戶外所接觸之塵埃般，測試其顏料耐蝕能力

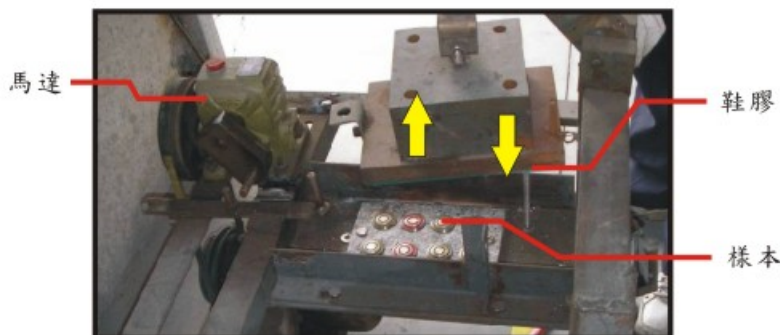

測試前



經過10天的測試後
(即約已壓踏131100步)之導行釘



*顏料名稱：酚醛磁漆（有防UV及耐磨特性。）

如需更多資料或有任何疑問，請與我們聯絡。

For more information, please contact us.

Tel: (852) 2873 2804, E-mail: sung@sunwayltd.com.hk

Fax: (852) 2814 0776, Website: <http://www.sunwaymetal.com/>

不銹鋼導行裝置 [Large Tactile Bolt]
Stainless Steel Tactile System [Large Tactile Bolt]

Large Tactile Bolt
有腳 [With Leg]

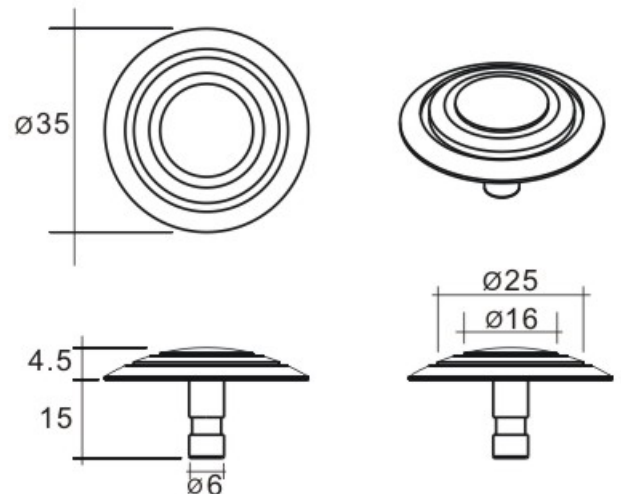
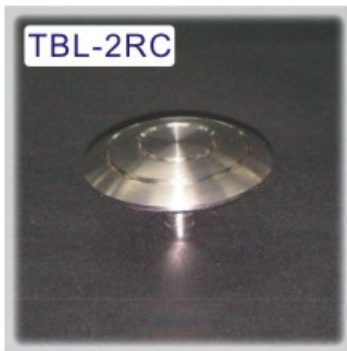

<u>Material:</u>	<input type="checkbox"/> S.S.304	<input type="checkbox"/> S.S.316	<u>Type:</u>	<input type="checkbox"/> Solid	<input type="checkbox"/> Shell
<u>Installation:</u>	<input type="checkbox"/> Epoxy	<input type="checkbox"/> Double Side Tape (Industrial use waterproof double side tape)			
<u>Color:</u>	<input type="checkbox"/> None	<input type="checkbox"/> Red	<input type="checkbox"/> Other: _____		

Large Tactile Bolt
無腳 [Without Leg]

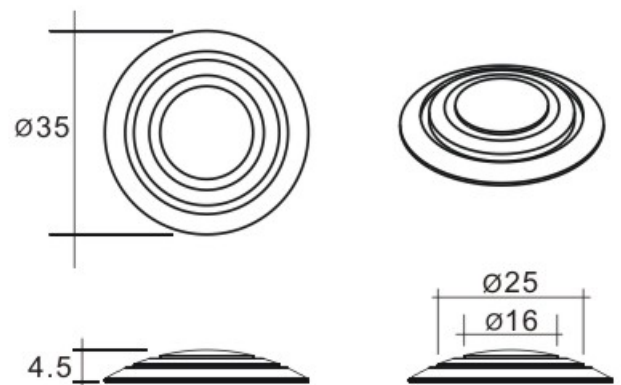
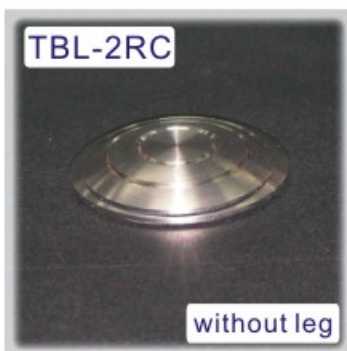

<u>Material:</u>	<input type="checkbox"/> S.S.304	<input type="checkbox"/> S.S.316			
<u>Installation:</u>	<input type="checkbox"/> Epoxy	<input type="checkbox"/> Double Side Tape (Industrial use waterproof double side tape)			
<u>Color:</u>	<input type="checkbox"/> None	<input type="checkbox"/> Red	<input type="checkbox"/> Other: _____		

如需更多資料或有任何疑問，請與我們聯絡。
For more information, please contact us.
Tel : (852) 2873 2804 , E-mail : sung@sunwayltd.com.hk
Fax: (852) 2814 0776 , Website : <http://www.sunwaymetal.com/>





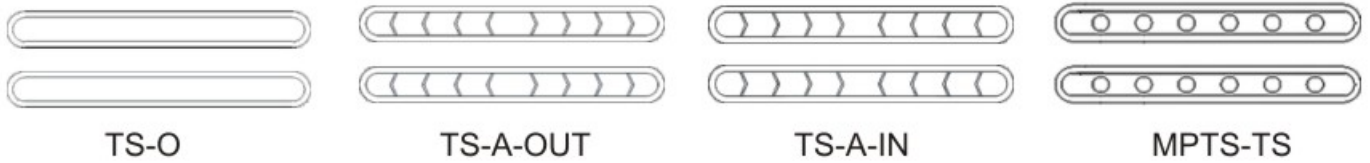

不銹鋼導行裝置 [Tactile Strip]

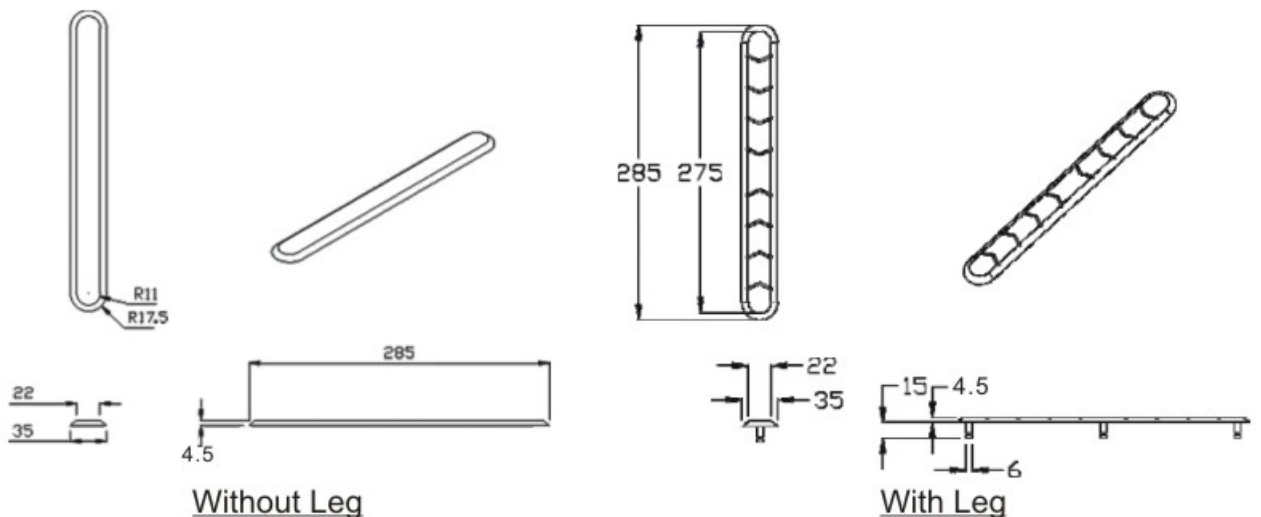
Stainless Steel Tactile System [Tactile Strip]



Tactile Strip Scale:



Model: Tactile Strip (TS)		
<input type="checkbox"/> TS-O	<input type="checkbox"/> TS-A-OUT	<input type="checkbox"/> TS-A-IN
		
Model: MPTS Strip (MPTS-TS)		
<input type="checkbox"/> MPTS-TS		
		
Material:	<input type="checkbox"/> S.S.304	<input type="checkbox"/> S.S.316
Leg:	 <input type="checkbox"/> With Leg	 <input type="checkbox"/> Without Leg
Installation:	<input type="checkbox"/> Epoxy	<input type="checkbox"/> Double Side Tape (Industrial use waterproof double side tape)
Color:	<input type="checkbox"/> Red	<input type="checkbox"/> Other: _____
<small>(For MPTS-TS model only)</small>		

如需更多資料或有任何疑問，請與我們聯絡。

For more information, please contact us.

Tel : (852) 2873 2804 , E-mail : sung@sunwayltd.com.hk

 Fax: (852) 2814 0776 , Website : <http://www.sunwaymetal.com/>

防水雙面膠貼不銹鋼防滑裝置
Waterproof Double Side Tape Anti-slip Tile

Bathroom is a place which accident happen usually, especially, falls down caused by wet floor, someone gets hurt as well as loses their life. This kind of accident almost account for 40% in the total domestic accident.

If your family members include Elderly, Expectant mother and Young Children, you should pay highly attention. However, you cannot always stay on their side, at that time Waterproof Double Side Tape Anti-slip Tile can help you to reduce the accident happen.

Double side tape anti-slip tile

- Saving time & manpower, instant installation & reliable.
- 2 Steps easy installation:
 - 1) Pull-off the mask 2) Paste on the floor
- Non-necessary to drill hole, keep the original floor.
- Easy to repair, do it yourself at any time.

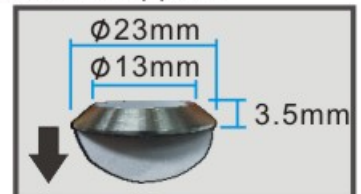

High pull-off force and waterproof double side tape, install easily and pass the twist and pull-off test tested by MaterialLab.

設有多款外觀選擇 材料：不銹鋼304 / S.S. 304(高級防水，防銹及環保材料)

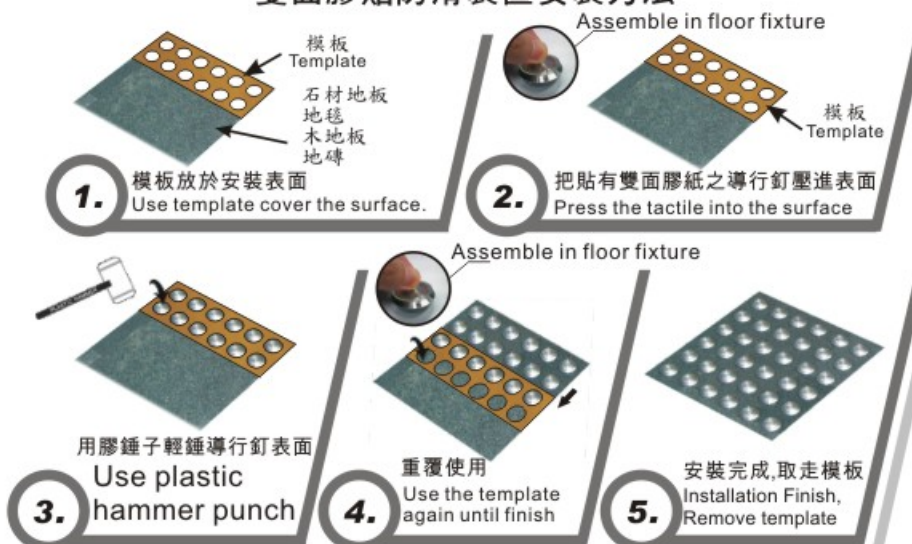
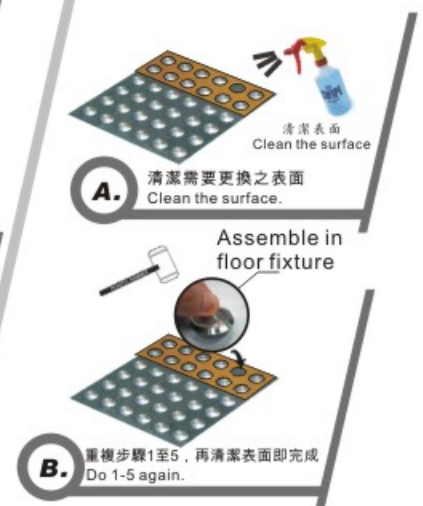

Application suitable on:
Bathroom or washroom in home, club house, elderly home and hotel.

雙面膠貼防滑裝置安裝方法

更換方法
Re-Installation Method

如需更多資料或有任何疑問，請與我們聯絡。

For more information, please contact us.

Tel : (852) 2873 2804 , E-mail : sung@sunwayltd.com.hk

Fax: (852) 2814 0776 , Website : <http://www.sunwaymetal.com/>